

SUCTION CUPS 1

PNEUMAX GREEN LINE: TECHNOLOGY & INNOVATION

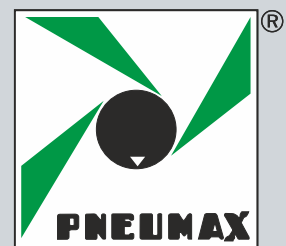

www.pneumaxspa.com

Standard round suction cup

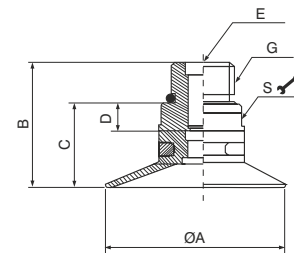
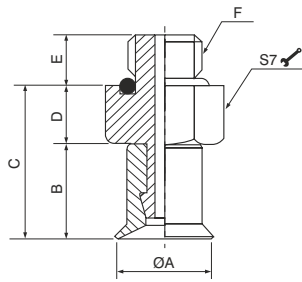

Code	ØA	B	C	D	E	F
19VTN.●.05.004.00	5	6.1	10.1	4	3.5	M5
19VTN.●.05.008.00	9	7	11	4	3.5	M5
19VTN.●.05.010.00	11	10.5	15.5	5	3.5	M5

Code	ØA	B	C	D	E	G	S
19VTN.●.18.020.00	22	15.5	9.5	1.5	M5	G1/8"	S12
19VTN.●.18.030.00	32	17	11	1.5	M5	G1/8"	S12
19VTN.●.18.040.00	42	25	18	5	-	G1/8"	S17
19VTN.●.14.050.00	53	32.5	23.5	6	-	G1/8"	S24

Standard round suction cup, suitable for gripping and moving with vacuum, objects with flat or slightly curved surfaces, allows gripping on concave surfaces.

Table of lifting forces

Code ● = Version N = NBR / S = Silicone	Volume cm ³	Lifting force in vertical direction (N)			Lifting force in parallel direction (N)			Weight (gr.)
		-20kPa	-60kPa	-90kPa	-20kPa	-60kPa	-90kPa	
19VTN.●.05.004.00	0.03	0.198	0.885	1.275	0.198	0.78	1	2.3
19VTN.●.05.008.00	0.1	1	2.55	3.8	1	2.85	3.35	2
19VTN.●.05.010.00	0.18	1.48	4.4	6.85	1.5	4.4	4.9	2.7
19VTN.●.18.020.00	1	5.9	12.2	16	5.9	8.8	9.8	3
19VTN.●.18.030.00	2	13	25	33	7.8	9.8	11	4.2
19VTN.●.18.040.00	5.5	20	37.5	60	13.8	22	27.5	11
19VTN.●.14.050.00	12	35.5	74	95	20	37	44	26.6

Material	Colour	Hardness °Shore A	Operating temperature °C
NBR	black	55	-20 ÷ 110
Silicone	red	50	-40 ÷ 200

Cup-style round suction cup

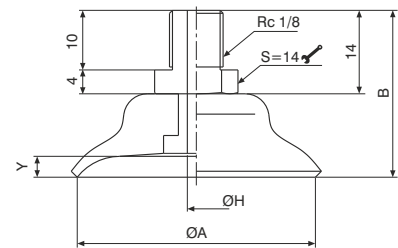
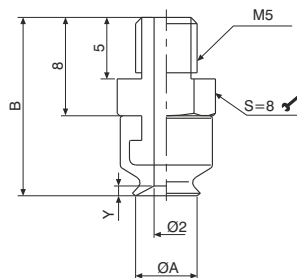

Code	ØA	B	Y
19VTC.N.05.006.00	6	14.5	0.8
19VTC.N.05.008.00	8	15	1.2
19VTC.N.05.010.00	10	15.5	1.5

Code	ØA	B	ØH	Y
19VTC.N.18.015.00	15	22	2	1.9
19VTC.N.18.020.00	20	24	3	2.3
19VTC.N.18.030.00	30	26	3	2
19VTC.N.18.040.00	40	28	3	3.5
19VTC.N.18.050.00	50	29	4	4

Typical cup-shaped suction cup, suitable for gripping and moving with vacuum, objects with flat or slightly curved surfaces, allows gripping on concave surfaces.

Table of lifting forces

Code	Volume cm ³	Lifting force in vertical direction (N)		Weight (gr.)
		-60kPa	-90kPa	
19VTC.N.05.006.00	0.03	0.5	0.8	2.3
19VTC.N.05.008.00	0.1	1	1.5	2.4
19VTC.N.05.010.00	0.18	1.5	2	2.5
19VTC.N.18.015.00	0.9	5	7.5	11.5
19VTC.N.18.020.00	2.5	8.5	11	13.6
19VTC.N.18.030.00	5	18	23	14.9
19VTC.N.18.040.00	12	30	35	19.4
19VTC.N.18.050.00	15	45	60	29.4

Material	Colour	Hardness °Shore A	Operating temperature °C
NBR	black	55	-20 ÷ 110

Round flat suction cup

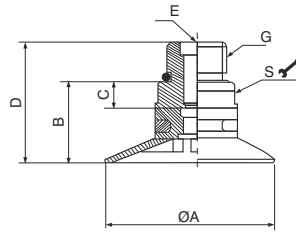

Code	ØA	B	C	D	E	G	S
19VTP.V.18.020.00	22	9.5	1.5	15.5	M5	G1/8"	S12
19VTP.V.18.025.00	27	10.5	1.5	16.5	M5	G1/8"	S12
19VTP.V.18.030.00	32	11.5	1.5	17.5	M5	G1/8"	S12
19VTP.V.18.040.00	42	18	5	25	-	G1/8"	S17
19VTP.V.14.050.00	53	22.5	6	32.5	-	G1/4"	S24

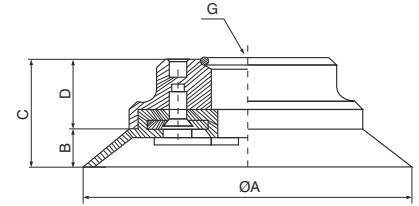

Code	ØA	B	C	D	G
19VTP.V.14.075.00	77	8	26	18	G1/4"
19VTP.V.12.110.00	112	14	29	15	G1/2"
19VTP.V.12.150.00	152	18	33	14	G1/2"

Flat round suction cup, suitable for gripping and moving with vacuum, objects with flat surfaces, offers good stability and minimal displacement. Recommended for applications with force parallel to grip plane, suitable for moving glass, wood, steel and plastic sheets. Internal reinforcements prevent thin objects from deforming and increase friction in applications with forces parallel to grip plane.

Table of lifting forces

Code V = Version N = NBR / S = Silicone	Volume cm ³	Lifting force in vertical direction (N)			Lifting force in parallel direction (N)			Weight (gr.)
		-20kPa	-60kPa	-90kPa	-20kPa	-60kPa	-90kPa	
19VTP.V.18.020.00	1	6	15	18.7	5	7.95	8.45	3.1
19VTP.V.18.025.00	1.1	9.2	19.3	24.9	7.95	8.95	10	3.6
19VTP.V.18.030.00	2	13	24.8	30.8	11	15.98	20	4.5
19VTP.V.18.040.00	4.8	20	40	50	15	25	29.5	11.5
19VTP.V.14.050.00	10	37	74	96	24	40	50	27.9
19VTP.V.14.075.00	20	80	201	272	60	110	140	121.3
19VTP.V.12.110.00	70	141	418.5	562	140	248	299.7	245.3
19VTP.V.12.150.00	160	300	845	1098	250	600	800	605

Material	Colour	Hardness °Shore A	Operating temperature °C
NBR	black	55	-20 ÷ 110
Silicone	red	50	-40 ÷ 200

Round bellows suction cup

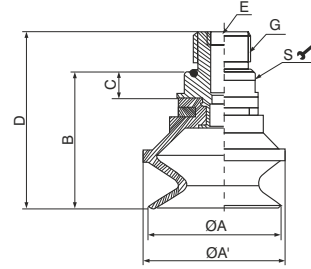
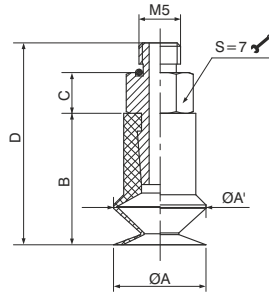

Code V = Version N = NBR / S = Silicone	ØA	ØA'	B	C	D
19VTS.V.05.005.15	5.6	6.2	9.2	4	16.7
19VTS.V.05.010.15	11	12	16	5	25
19VTS.V.05.015.15	15.5	17.5	19.5	5	28.5

Code V = Version N = NBR / S = Silicone	ØA	ØA'	B	C	D	E	G	S
19VTS.V.18.020.15	22	24	20.5	1.5	26.5	M5	G1/8"	S12
19VTS.V.18.030.15	34	36	31	5	38	-	G1/8"	S17
19VTS.V.18.040.15	43	46	33	5	40	-	G1/8"	S17
19VTS.V.14.050.15	53	58	41	6	50	-	G1/4"	S24

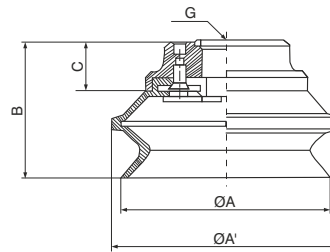

Code V = Version N = NBR / S = Silicone	ØA	ØA'	B	C	G
19VTS.V.12.075.15	78	83	50	18	G1/2"
19VTS.V.12.110.15	115	124	63	15	G1/2"
19VTS.V.12.150.15	155	166	78	14	G1/2"

Round bellows suction cup, which, due to its shape, ensures that when in contact with the surface of the load to be lifted and in the presence of vacuum, it rapidly collapses, releasing the load of several millimetres, separately from the movements of the automation system; this rapid movement prevents the load underneath from remaining stuck to the one being lifted. For this reason, suction cups with this feature are recommended in cases where you need to pick off and move sheets of cardboard, fine sheets, wood panels, glass panes etc. and are also recommended for use on curved surfaces. This suction cup is not suitable for handling objects with lifting force parallel to the surface.

Table of lifting forces

Code V = Version N = NBR / S = Silicone	Volume cm ³	Lifting force in vertical direction (N)			Weight (gr.)
		-20kPa	-60kPa	-90kPa	
19VTS.V.05.005.15	0.05	0.295	0.786	0.99	2
19VTS.V.05.010.15	0.48	1.7	3.5	5.1	2.9
19VTS.V.05.015.15	1.1	3.3	6	8.9	3.5
19VTS.V.18.020.15	2.7	5.8	10.6	15	5
19VTS.V.18.030.15	10	13	25	28	13.6
19VTS.V.18.040.15	15	22.5	42	50.2	20.2
19VTS.V.14.050.15	32	34	65	83	39.5
19VTS.V.12.075.15	110	74	166.4	226	131.3
19VTS.V.12.110.15	310	136.5	343	460.5	316.6
19VTS.V.12.150.15	650	295	686	883	733.3

Material	Colour	Hardness °Shore A	Operating temperature °C
NBR	black	55	-20 ÷ 110
Silicone	red	50	-40 ÷ 200

Long bellows suction cup

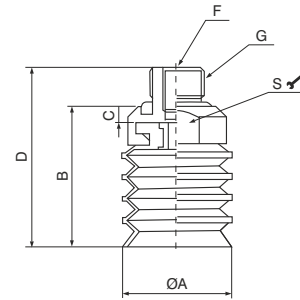
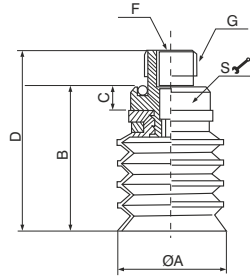

Code	ØA	B	C	D	F	G	S
19VTS.●18.020.45	20	24.5	1.5	30.5	M5	G1/8"	S12
19VTS.●18.030.45	30	37	5	44	-	G1/8"	S17
19VTS.●18.040.45	40	17	5	24	-	G1/8"	S17
19VTS.●14.050.45	50	58	6	67	-	G1/4"	S24

Code	ØA	B	C	D	F	G	S	Weight (gr.)
19VTS.S.18.020.45	20	26	3	27	M5	G1/8"	S16	5.9

Long bellows suction cup which, due to its shape, makes it possible to compensate for differences in height. Its upward movements are particularly suitable for the separation of thin products, and suitable for handling food packed in plastic bags and for fragile objects. This suction cup is not suitable for handling objects with lifting force parallel to the surface.

Table of lifting forces

Code	Volume cm ³	Lifting force in vertical direction (N)		Weight (gr.)
		-20kPa	-60kPa	
19VTS.●18.020.45	4	0.3	0.6	3.9
19VTS.●18.030.45	13	0.6	1.55	12.4
19VTS.●18.040.45	27	1.05	2.15	19.8
19VTS.●14.050.45	55	1.68	4.22	38.3

Material	Colour	Hardness °Shore A	Operating temperature °C
NBR	black	55	-20 ÷ 110
Silicone	red	50	-40 ÷ 200

Long bellows suction cup for bags

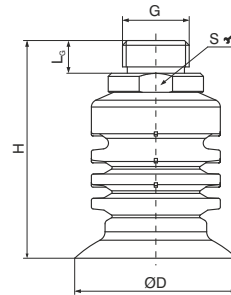

Code	D	H	G	L	S
19VTS.S.14.030.35	30.5	51.5	G1/4"	9	19
19VTS.S.38.040.35	40	56	G3/8"	10	22
19VTS.S.12.050.35	50	69	G1/2"	10	28

The long bellows suction cup is especially suited for the movement of bags, thanks to its very thin lip and internal notchings, which allow it to ensure secure gripping even with heavy bags that are difficult to lift.

Table of lifting forces

Code	Volume cm ³	Lifting force in vertical direction (N)	Weight (gr.)
		-60kPa	
19VTS.S.14.030.35	8.5	9	17.6
19VTS.S.38.040.35	14	15	23.6
19VTS.S.12.050.35	26	25	44.2

Material	Colour	Hardness °Shore A	Operating temperature °C
Silicone	red	40	-40 ÷ 200

High friction round suction cup

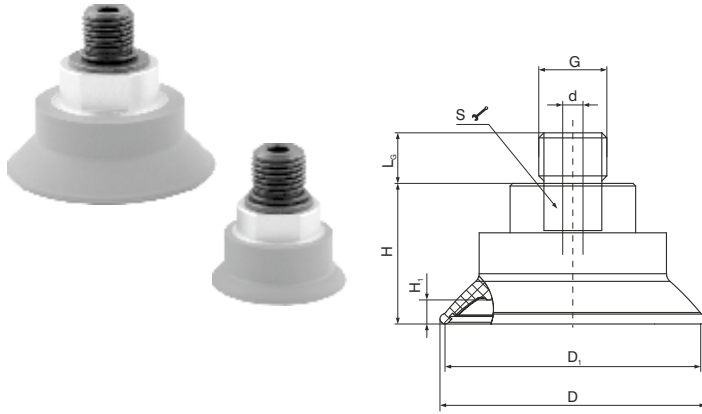

Code	D	D ₁	d	G	H	L _g	S	H ₁
19GTN.N.14.030.00	32	30	4	G1/4M	20	12	17	2.7
19GTN.N.14.040.00	42	40	4	G1/4M	22	12	17	3.7
19GTN.N.14.050.00	52	50	6	G1/4M	28	12	22	4.7
19GTN.N.14.060.00	62.5	60	6	G1/4M	31	12	22	6
19GTN.N.14.080.00	82	80	6	G1/4M	34	12	22	7.5
19GTN.N.14.100.00	103	100	6	G1/4M	36	12	22	9.2

High friction round suction cup suitable for movement of pieces of various size and shape, reinforced internal structure ensures that lifted objects are not deformed and increases friction force in applications with force parallel to the grip plane. The innovative design of the support plane inside the suction cup ensures high coefficient of friction with the grip surface, in particular on very oily sheets or glass panes and very wet marble, thanks to this suction cup's drainage capability. This suction cup is most particularly recommended for applications of handling sheet metal parts in the "automotive" industry. This characteristic means that there is a secure and solid grip by the suction cup and consequently ensures accurate positioning of the load to be moved.

Table of lifting forces

Code	Volume cm ³	Lifting force in vertical direction (N)	Lifting force in parallel direction (N)	Lateral force on oily surface (N)	Weight (gr.)
		-60kPa	-60kPa	-60kPa	
19GTN.N.14.030.00	1.6	45	35	33	28.3
19GTN.N.14.040.00	3.5	72	54	51	30.1
19GTN.N.14.050.00	7.5	112	90	86	55.4
19GTN.N.14.060.00	12.6	145	102	93	62.6
19GTN.N.14.080.00	35	288	212	190	81.4
19GTN.N.14.100.00	60	445	322	308	96.6

Material	Colour	Hardness °Shore A	Operating temperature °C
NBR	Orange	60	-20 ÷ 110

High friction round bellows suction cup

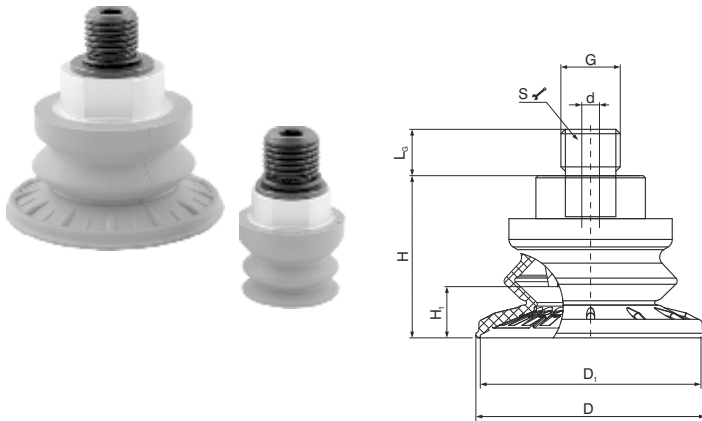

Code	D	D ₁	d	G	H	L _g	S	H ₁
19GTS.N.14.022.15	22	20	4	G1/4M	25	12	16	5.5
19GTS.N.14.030.15	32	30	4	G1/4M	28	12	17	9.5
19GTS.N.14.040.15	42	40	4	G1/4M	28.5	12	17	10
19GTS.N.14.050.15	52	50	6	G1/4M	37	12	22	11.5
19GTS.N.14.060.15	62.5	60	6	G1/4M	41	12	22	14.5
19GTS.N.14.080.15	82	80	6	G1/4M	50.5	12	22	22.5
19GTS.N.14.100.15	102.5	100	6	G1/4M	56	12	22	25

High friction round bellows suction cup suited for movement of pieces of various size and shape and where level compensation is necessary, such as when withdrawing from loaders. Especially recommended for applications with force parallel to the grip plane. The innovative design of the support plane inside the suction cup ensures high coefficient of friction with the grip surface, in particular on very oily sheets or glass panes and very wet marble, thanks to this suction cup's drainage capability. This feature enables a secure and solid grip by the suction cup and consequently ensures accurate positioning of the load to be moved.

Table of lifting forces

Code	Volume cm ³	Lifting force in vertical direction (N)	Lifting force in parallel direction (N)	Lateral force on oily surface (N)	Weight (gr.)
		-60kPa	-60kPa	-60kPa	
19GTS.N.14.022.15	1.5	23	20	6.5	25.2
19GTS.N.14.030.15	6.3	35	28	12	29.5
19GTS.N.14.040.15	7.2	62	37	34	30.9
19GTS.N.14.050.15	11.2	85	58	55	56.3
19GTS.N.14.060.15	22.5	141	88	83	64.4
19GTS.N.14.080.15	57	236	141	136	86.4
19GTS.N.14.100.15	92	371	228	221	116.6

Material	Colour	Hardness °Shore A	Operating temperature °C
NBR	Orange	60	-20 ÷ 110

High friction oval suction cup

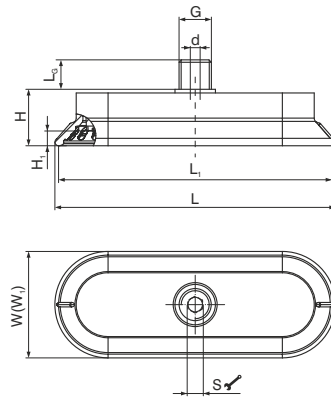

Code	L	L ₁	W	W ₁	d	G	H	L ₀	S	H ₁
19GEN.N.14.AxH.00	84	82	24	22	6	G1/4M	17	12	6	5
19GEN.N.14.BxL.00	93	90	33	30	6	G1/4M	17.5	12	6	6
19GEN.N.14.CxN.00	113	110	43	40	6	G1/4M	23	12	6	6

High friction oval suction cup suitable for movement of elongated thin pieces; the reinforced internal structure ensures that lifted objects are not deformed and increases friction force in applications with force parallel to the grip plane. The innovative design of the support plane inside the suction cup ensures high coefficient of friction with the grip surface, in particular on very oily sheets or glass panes and very wet marble, thanks to this suction cup's drainage capability. This suction cup is most particularly recommended for applications of handling sheet metal parts in the "automotive" industry. This feature enables a secure and solid grip by the suction cup and consequently ensures accurate positioning of the load to be moved.

Table of lifting forces

Code	Volume cm ³	Lifting force in vertical direction (N)	Lifting force in parallel direction (N)	Lateral force on oily surface (N)	Weight (gr.)
		-60kPa	-60kPa	-60kPa	
19GEN.N.14.AxH.00	15	75	38	35	38.6
19GEN.N.14.BxL.00	18	120	77	60	41.5
19GEN.N.14.CxN.00	35	200	188	118	71.9

Material	Colour	Hardness °Shore A	Operating temperature °C
NBR	Orange	60	-20 ÷ 110

Oval high-friction bellows suction cup

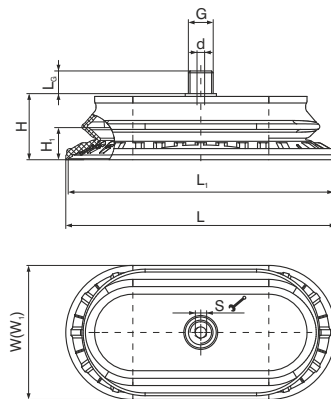

Code	L	L ₁	W	W ₁	d	G	H	L ₀	S	H ₁
19GES.N.14.BxF.15	62	60	32	30	6	G1/4M	21.5	12	6	6
19GES.N.14.CxH.15	82	80	42	40	6	G1/4M	24.5	12	6	8.8
19GES.N.14.ExN.15	112	110	57	55	6	G1/4M	30.5	12	6	12.5
19GES.N.14.GxR.15	143	140	72	69	6	G1/4M	35	12	6	17

High friction oval bellows suction cup suited for movement of elongated and thin pieces and where level compensation is necessary, such as in the withdrawal of loaders. Especially recommended for applications with force parallel to the grip plane. The innovative design of the support plane inside the suction cup ensures a high coefficient of friction with the grip surface, in particular on very oily sheets or glass panes and very wet marble, thanks to this suction cup's drainage capability. This feature enables a secure and solid grip by the suction cup and consequently ensures accurate positioning of the load to be moved.

Table of lifting forces

Code	Volume cm ³	Lifting force in vertical direction (N)	Lifting force in parallel direction (N)	Lateral force on oily surface (N)	Weight (gr.)
		-60kPa	-60kPa	-60kPa	
19GES.N.14.BxF.15	8.7	53	60	50	41.9
19GES.N.14.CxH.15	22	110	118	101	51.5
19GES.N.14.ExN.15	57	197	200	183	102.1
19GES.N.14.GxR.15	108	275	295	267	138.9

Material	Colour	Hardness °Shore A	Operating temperature °C
NBR	Orange	60	-20 ÷ 110

Standard round suction cup made of polyurethane

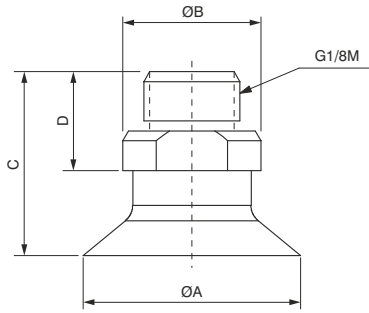

Code	ØA	ØB	C	D
19VTN.P.18.030.00	31	14	20.5	10
19VTN.P.18.040.00	41	14	24	10

Standard round suction cup made of polyurethane, suitable for gripping and moving with vacuum, objects with flat or slightly curved surfaces, allows gripping on concave surfaces. The main advantage of this suction cup is that the material it is made of—polyurethane—lasts longer than other materials, has optimum wear resistance, good flexibility and Polyurethane suction cups are mark resistant.

Table of lifting forces

Code	Volume cm ³	Lifting force in vertical direction (N)			Lifting force in parallel direction (N)			Weight (gr.)
		-20kPa	-60kPa	-90kPa	-20kPa	-60kPa	-90kPa	
19VTN.P.18.030.00	2	13	23	33	7.8	9.8	11	5
19VTN.P.18.040.00	5.5	20	40	60	13.8	22	27.5	11.8

Material	Colour	Hardness °Shore A	Operating temperature °C
PU	yellow	40	10 ÷ 50

Round bellows suction cup made of polyurethane

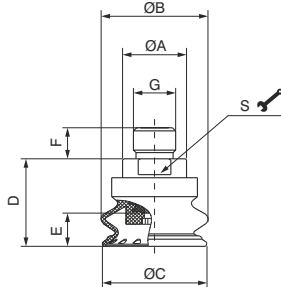

Code	ØA	ØB	ØC	D	E	F	G	S
19VTS.P.14.030.15	19.8	32	32	28	7	13.5	G1/4" thread male	17
19VTS.P.14.040.15	19.8	32	42	29	9	13.5	G1/4" thread male	22
19VTS.P.14.050.15	25	40	51.5	37	11.5	13.5	G1/4" thread male	22

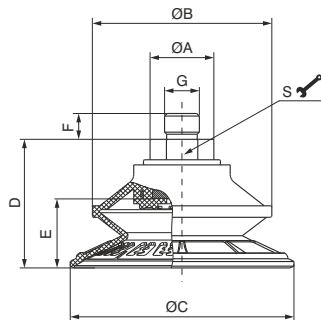

Code	ØA	ØB	ØC	D	E	F	G	S
19VTS.P.14.060.15	24	50	64	41.5	15	13.5	G1/4" thread male	21
19VTS.P.14.080.15	24	68	84	49.5	22.5	13.5	G1/4" thread male	21
19VTS.P.14.100.15	24	83	103	55	20.5	13.5	G1/4" thread male	22

Round bellows suction cup made of polyurethane, suited for moving pieces of various sizes and shapes and where level compensation is necessary, such as when withdrawing from loaders. The big advantage of this suction cup is that the material it is made of—polyurethane—lasts longer than other materials, has optimum wear resistance, good flexibility and optimum tensile strength. Suitable for moving—with vacuum—steel sheets, glass sheets, cardboard boxes and wood panels.

Table of lifting forces

Code	Volume cm ³	Lifting force in vertical direction (N)			Lifting force in parallel direction (N)			Weight (gr.)
		-20kPa	-60kPa	-90kPa	-20kPa	-60kPa	-90kPa	
19VTS.P.14.030.15	6	11	60.2	91	8.4	30.5	76	30
19VTS.P.14.040.15	7.2	17.5	93	119.8	11.3	63.8	110.8	30.6
19VTS.P.14.050.15	11	25	128.5	157.8	20.5	94	144	58.5
19VTS.P.14.060.15	22	87.3	156.2	189.2	67	125.6	165.8	67.9
19VTS.P.14.080.15	59.5	118.6	210.5	252.6	89	167.8	221.2	89.9
19VTS.P.14.100.15	103.5	149	269.5	310.4	111.8	209.8	276.5	135.3

Material	Colour	Hardness °Shore A	Operating temperature °C
PU	Blue	60	10 ÷ 50

Round bellows suction cup made of polyurethane

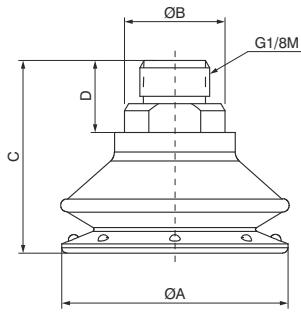

Code	ØA	ØB	C	D
19VTS.P:18.030.15	31.5	14	26.8	10
19VTS.P:18.040.15	42	14	32.4	10

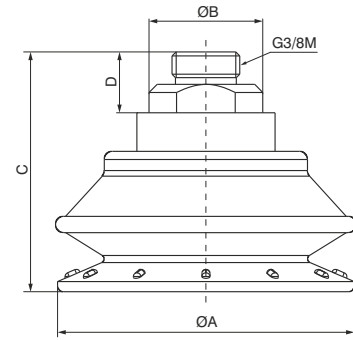

Code	ØA	ØB	C	D
19VTS.P:38.050.15	52.5	28	44.3	16

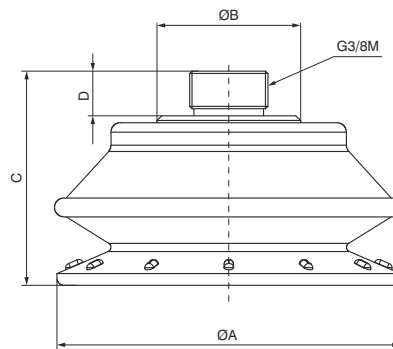

Code	ØA	ØB	C	D
19VTS.P:38.070.15	73	30.5	45.5	10

Round bellows suction cup made of polyurethane, suited for movement of pieces of various size and shape and where level compensation is necessary, such as when withdrawing from loaders. The big advantage of this suction cup is that the material it is made of—polyurethane—lasts longer than other materials, has optimum wear resistance, good flexibility and optimum tensile strength. Polyurethane suction cups are mark resistant.

Table of lifting forces

Code	Volume cm ³	Lifting force in vertical direction (N)			Weight (gr.)
		-20kPa	-60kPa	-90kPa	
19VTS.P:18.030.15	10	13	30	37	10.3
19VTS.P:18.040.15	15	22.5	60	75	17.3
19VTS.P:38.050.15	32	34	86	100	33.4
19VTS.P:38.070.15	108	74	165	225	60.6

Material	Colour	Hardness °Shore A	Operating temperature °C
PU	yellow	40	10 ÷ 50

Round bellows suction cup made of polyurethane

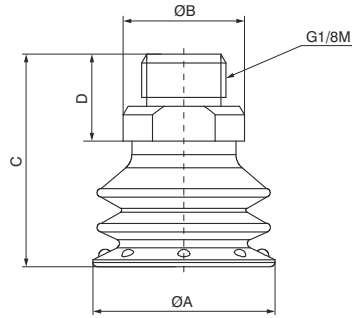

Code	ØA	ØB	C	D
19VTS.P.18.020.25	21	14	39	10
19VTS.P.18.030.25	30	14	31.3	10

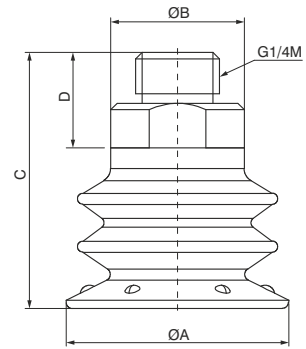

Code	ØA	ØB	C	D
19VTS.P.14.040.25	40	21	43.5	15

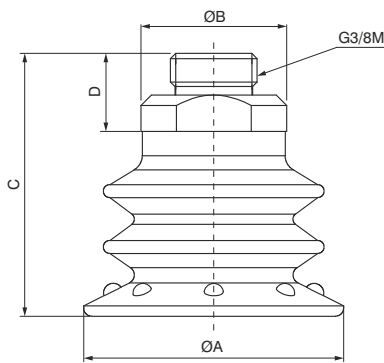

Code	ØA	ØB	C	D
19VTS.P.38.050.25	50	18	51.5	16

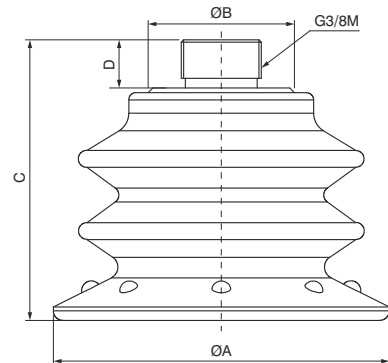

Code	ØA	ØB	C	D
19VTS.P.38.070.25	70	30.5	58.5	10

Round bellows suction cup made of polyurethane, suited for movement of pieces of various size and shape and where level compensation is necessary, such as when withdrawing from loaders. The big advantage of this suction cup is that the material it is made of—polyurethane—lasts longer than other materials, has optimum wear resistance, good flexibility and optimum tensile strength. Suitable for moving porous objects or ones with an irregular surface, such as cardboard. Polyurethane suction cups are mark resistant.

Table of lifting forces

Code	Volume cm ³	Lifting force in vertical direction (N)			Weight (gr.)
		-20kPa	-60kPa	-90kPa	
19VTS.P.18.020.25	1.18	4.5	7	10	4.2
19VTS.P.18.030.25	9	10	19	25	6.9
19VTS.P.14.040.25	15	15	32	50	18.2
19VTS.P.38.050.25	30	35	58	79	32.6
19VTS.P.38.070.25	75	72	125	150	60.5

Material	Colour	Hardness °Shore A	Operating temperature °C
PU	Green	55	10 ÷ 50

Foam rubber round suction cup

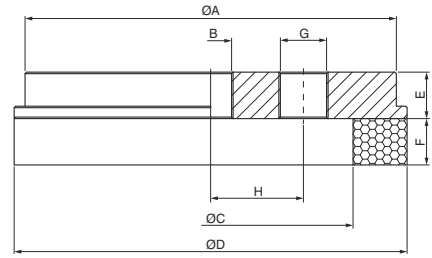
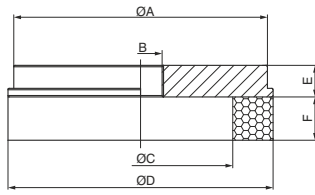

Code	ØA	B	ØC	ØD	E	F
19VTN.G.14.040.00	40	G1/4"	20	40	10	15
19VTN.G.14.064.00	60	G1/4"	40	64	10	15
19VTN.G.14.092.00	88	G1/4"	64	92	11	15

Code	ØA	B	ØC	ØD	E	F	G	H
19VTN.G.14.127.00	120	G1/4"	92	127	15	15	G3/8"	30

Foam rubber round suction cup is made from a special mixture called "NR", which has a density that allows for gripping even on very rough and irregular surfaces, and allows its elasticity to be maintained even after several working cycles. Especially suited for moving loads with coarse or very rough surfaces such as: sawn, bush-hammered or flamed marble, textured, non-slip or ribbed/corrugated sheets, brick, items made of rough concrete, garden walkway tiles, etc., and in general in all cases where traditional suction cups cannot be used. Recommended for handling loads with lifting force parallel to the surface and for the movement of loads with oiled surfaces.

Table of lifting forces

Code	Lifting force in vertical direction (N)	Weight (gr.)
	-60kPa	
19VTN.G.14.040.00	7.8	33.4
19VTN.G.14.064.00	35	82.4
19VTN.G.14.092.00	84	197.8
19VTN.G.14.127.00	172	489.3

Material	Colour	Hardness °Shore A	Operating temperature °C
Foam rubber "NR"	Orange	30	-20 ÷ 80

Foam rubber rectangular suction cup

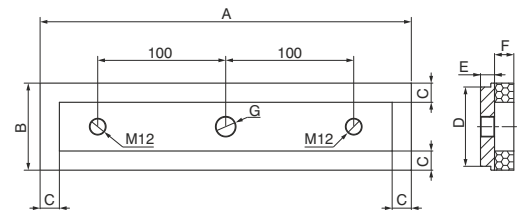
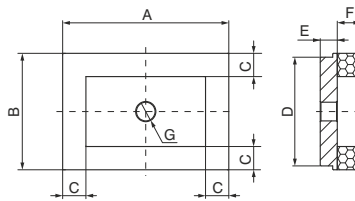
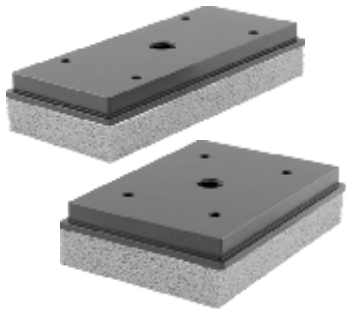

Code	A	B	C	D	E	F	G
19VRN.G.22.NxH.00	107	75	15	70	11	15	M12
19VRN.G.22.RxF.00	135	60	15	55	11	15	M12

Code	A	B	C	D	E	F	G
19VRN.G.12.SxR.00	290	140	15	134	11	15	G1/2"

Foam rubber rectangular suction cup is made from a special mixture called "NR", which has a density that allows for gripping even on very rough and irregular surfaces, and allows its elasticity to be maintained even after several working cycles. Especially suited for movement of loads with coarse or very rough surfaces such as: sawn, bush-hammered or flamed marble, textured, non-slip or ribbed/corrugated sheets, brick, items made of rough concrete, garden walkway tiles, etc. and in general in all cases where traditional suction cups cannot be used. Not recommended for handling loads with lifting force parallel to the surface or for the movement of loads with oiled surfaces.

Table of lifting forces

Code	Lifting force in vertical direction (N)	Weight (gr.)
	-60kPa	
19VRN.G.22.NxH.00	88	236.7
19VRN.G.22.RxF.00	79	231.7
19VRN.G.12.SxR.00	706	1175.1

Material	Colour	Hardness °Shore A	Operating temperature °C
Foam rubber "NR"	Orange	30	-20 ÷ 80