



Vacuum generation | Oil-lubricated vacuum pumps

Rotary vane vacuum pumps – oil-lubricated

Rotary vane vacuum pumps – oil-lubricated



Product notes

- > High final vacuum
- > Suitable for moist environments
- > Effective damping and recovery system with by-pass and novel float valve guarantees oil-free exhaust air
- > Innovative sealing system prevents oil recirculation at standstill under vacuum
- > Elastic motor coupling effectively absorbs shocks
- > Horizontal mounting position
- > Protection class IP55
- > Complies with energy efficiency class IE3 according to EC regulation 640/2009
- > Please use item no. with index -A (e.g. DO.106C-3-A) for 60 Hz power frequency
- > Scope of supply: Condensate exhaust filter, gas ballast, oil non-return valve, oil SW 100

Notes

- > Designed for continuous operation for vacuum level between 60 % to 99.9 %, gas ballast available, can tolerate water vapor

Technical data

Item no.	DO.106C-3 (50 Hz)	DO.151C-3 (50 Hz)	DO.205C-3 (50 Hz)	DO.305C-3 (50 Hz)
Suction power at 50 Hz [m ³ /h]	106	151	205	305
Suction power at 60 Hz [m ³ /h]	127	181	245	365
Final pressure abs. [mbar (psi)]	0.1 (0)	0.1 (0)	0.5 (0)	0.5 (0)
Gas ballast	Yes	Yes	Yes	Yes
Max. inlet pressure for water vapour [mbar (psi)]	11 (0.2)	25 (0.4)	25 (0.4)	25 (0.4)
Water vapor capacity [l/h]	1	1.4	3.5	5
Check valve	Yes	Yes	Yes	Yes
Power supply at 50 (60) Hz [V]	Delta: 230 (230) Star: 400 (460)	Delta: 230 (230) Star: 400 (460)	Delta: 230 (230) Star: 400 (460)	Delta: 230 (230) Star: 400 (460)
Current consumption at 50 (60) Hz [A]	Delta: 8.6 (11.8) Star: 5 (5.9)	Delta: 12.2 (14.4) Star: 7 (7.2)	Delta: 19 (21.4) S tar: 11 (10.7)	Delta: 26 (32) Star: 15 (16)
Rated power at 50 (60) Hz [kW]	2.2 (2.7)	3.3 (3.7)	5.5 (6.6)	7.5 (9)
Noise level at 50 (60) Hz [dB(A)]	66 (68)	68 (70)	72 (74)	74 (76)
Operating temperature [°C (°F)]	75 - 85 (167 - 185)	75 - 85 (167 - 185)	70 - 80 (158 - 176)	75 - 85 (167 - 185)
Weight [kg]	70.5	80	170	180
Suitable accessories	Spare part kit: KIT-DO.105C/K*** Spare part kit: KIT-DO.105C/G* Pre-filter: FB 40	Spare part kit: KIT-DO.150C/K*** Spare part kit: KIT-DO.150C/G* Pre-filter: FB 50 Pre-filter: FB 60	Spare part kit: KIT-DO.205C/K*** Spare part kit: KIT-DO.205C/G** Pre-filter: FB 50 Pre-filter: FB 60	Spare part kit: KIT-DO.305C/K*** Spare part kit: KIT-DO.305C/G** Pre-filter: FB 60



Dimensions

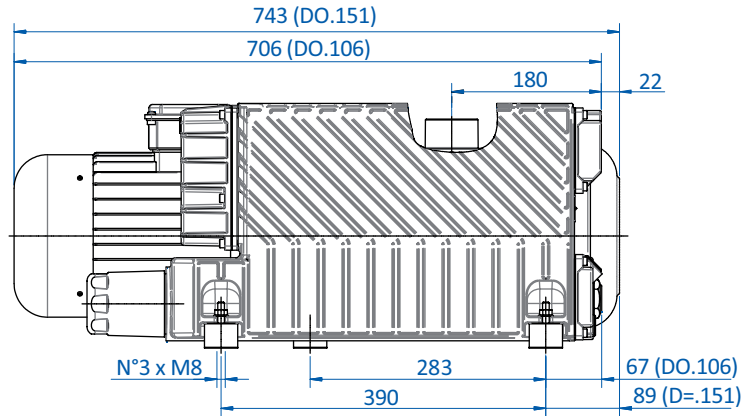
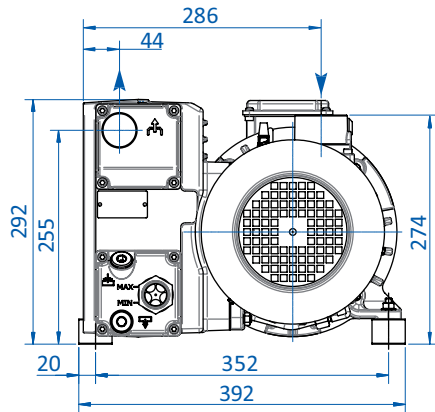

DO.106C-3 (50 Hz) | DO.151C-3 (50 Hz)

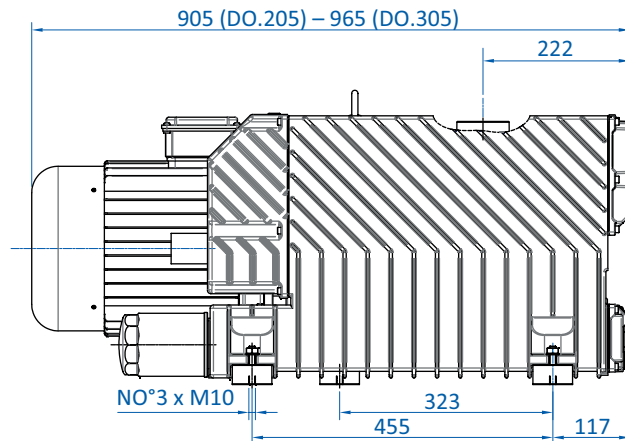
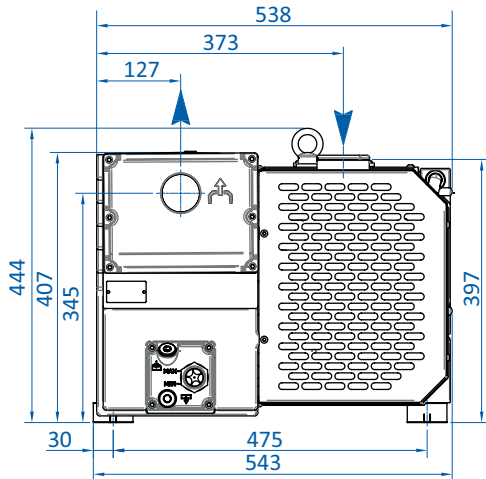

DO.205C-3 (50 Hz) | DO.305C-3 (50 Hz)

* = Rubber link, seals, 3 vanes, FKM shaft seal, FKM O-rings, oil filter with bypass pipe, gas ballast pipe, filters, oil inspection glass
 ** = Rubber link, FKM and NBR O-rings, 3 x vanes, oil recirculation pipe, gas ballast pipe, filters, oil inspection glass
 *** = Oil filter with bypass valve, exhaust filter, gasket

Diagrams

> Suction power against vacuum level at 50 Hz

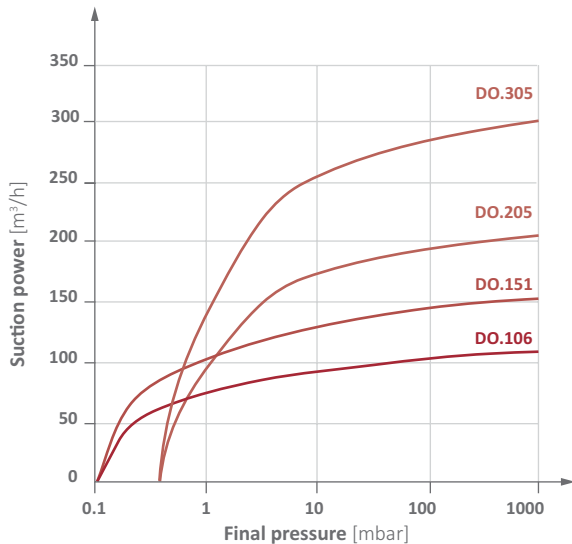

> Suction power against vacuum level at 60 Hz

