

HIGH PERFORMANCE BUTTERFLY VALVE HP 111-E



Wafer type butterfly valve in double-eccentric construction. Reliable sealing even with extreme temperature and pressure conditions.

TECHNICAL DATA

Nominal diameter:	DN 50 - DN 200 (larger nominal diameter on request)
Face-to-face:	EN 558 Series 20 ISO 5752 Series 20 API 609 Table 1
Flange accommodation:	EN 1092 PN 10/16 ASME Class 150 AS 4087 PN16/21
Flange Surface Design:	EN 1092, Form A/B, ASME RF,FF
Top flange:	EN ISO 5211
Marking:	EN 19
Tightness check	
- for R-PTFE seat:	EN 12266 (Leakage rate A)
- for Inconel seat:	EN 12266 (Leakage rate B) ISO 5208, Category 3
Temperature range:	-60°C to +600°C
Differential pressure:	see pressure/ temperature diagram
Vacuum:	up to 1mbar absolute

FEATURES

- Shut-off and control of gaseous and liquid media
- Disc and shaft have double-eccentric bearing
- Centering pieces can be used as installation aid
- Two seat ring systems available: R-PTFE and Inconel
- Seal variants
soft-sealing (R-PTFE) max. 230°C
metallic sealing (Inconel-seat) max. 600°C
- Maintenance-free
- Long service life, even at high switching frequencies
- FIRE SAFE BS 6755 PART 2

GENERAL APPLICATIONS

- Chemical and petrochemical industries
- Hot water and steam systems
- District heat supply
- Vacuum systems
- Shipbuilding
- Gas process technology
- Food industries
- Heavy duty services



The splitted shaft design allows better flow characteristics up to a nominal pressure of 19 bar.

HIGH PERFORMANCE BUTTERFLY VALVE HP 111-E

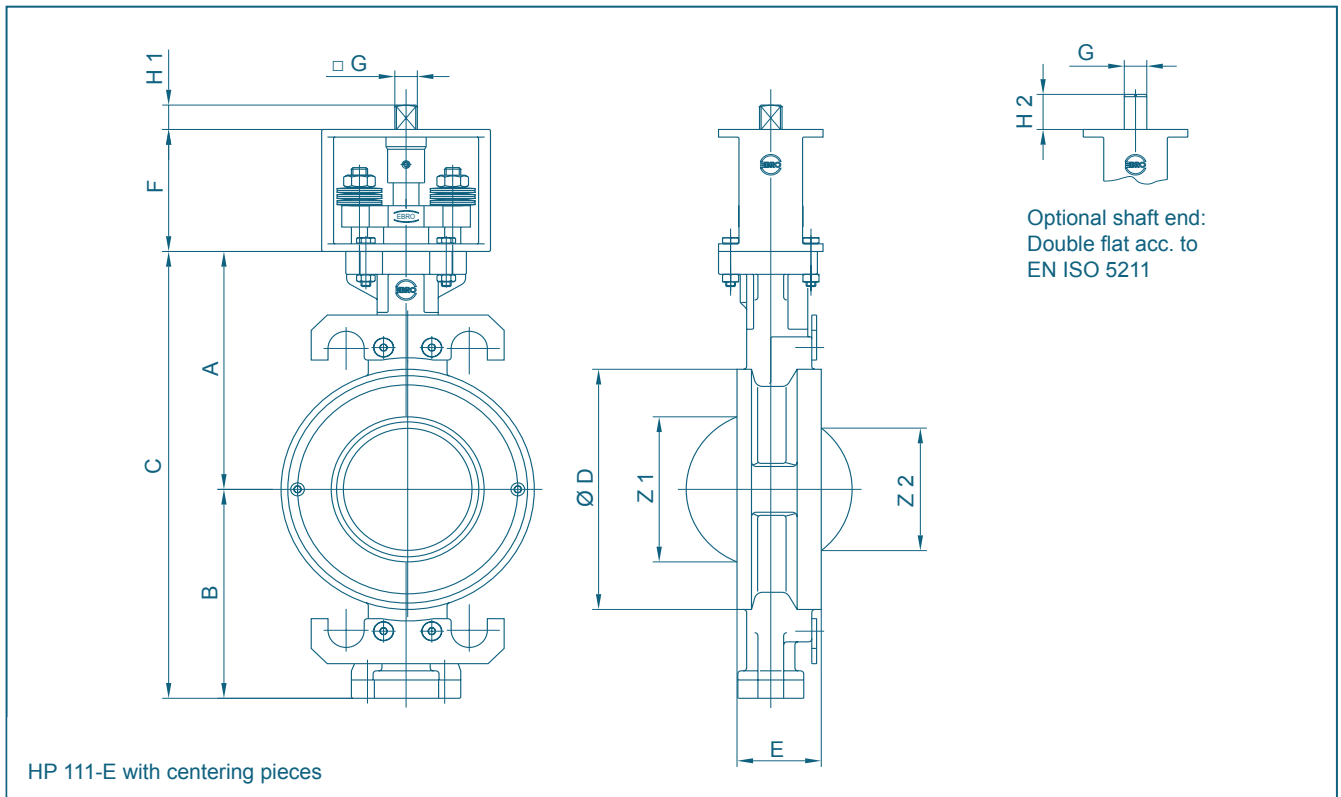

DN [mm]	Size [in]	Dimensions [mm]													min. pipe-Ø	Weight [kg]
		A	B	C	D	E	F	Flange	□G	H1	G	H2	Z1	Z2		
50	2	131	112	243	112	43	80	F05	12	15	14	23	41	-	51	5,8
65	2½	131	112	243	112	43	80	F05	12	15	14	23	41	-	51	5,8
80	3	141	122	263	138	46	80	F05	12	15	14	23	71	55	80	5,9
100	4	156	137	293	158	52	80	F05	12	15	14	23	95	82	103	7,4
125	5	180	172	352	186	56	80	F07	14	18	17	28	115	106	124	11,3
150	6	194	186	380	216	56	80	F07	14	18	17	28	144	136	151	13,8
200	8	219	212	431	270	60	80	F10	17	18	22	37	188	182	196	24,6

Subject to change without notice

HIGH PERFORMANCE BUTTERFLY VALVE HP 111-E

MATERIAL SPECIFICATION AND PARTS LIST

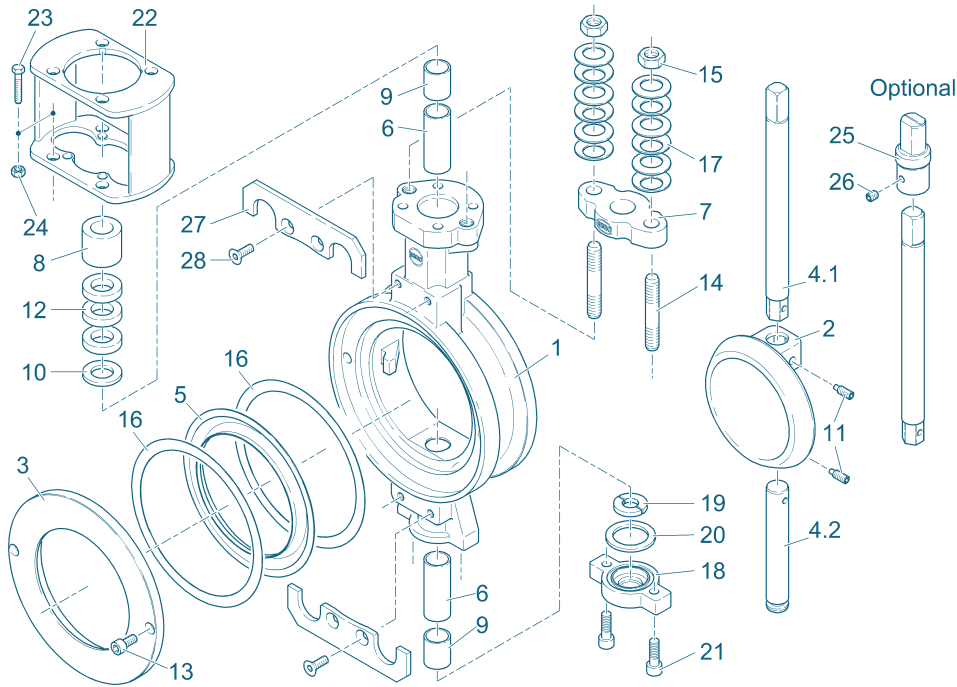

Pt.	Description	Material	Material-No.	ASTM	Pt.	Description	Material	Material-No.	ASTM
1	Body				14	Threaded pin			
	Carbon Steel	GP240GH (GS-C25N)	1.0619	WCB		Stainless Steel	A2-70	1.4301	B 8
	Stainless Steel	G-X5CrNiMo19-11	1.4408	CF8M	15	Hex. nut			
2	Disc					Stainless Steel	A 2	1.4301	8
	Stainless Steel	G-X5CrNiMo19-11	1.4408	CF8M	16	Graphite seal (for metal seat)			
3	Clamping ring					Graphite			
	Steel	S23JR (RSI37-2)	1.0038	283-C	17	Belleville spring washer			
	Stainless Steel	X5CrNiMo17-12-2	1.4401	316		Spring Steel	50CrV4	1.8159	6150
4.1	Upper shaft					Stainless Steel	X10CrNi18-8	1.4310	301 Ti
	Stainless Steel	X4CrNiMo16-5-1	1.4418		18	Cover plate			
	Stainless Steel	X5CrNiCuNb16-4	1.4542			Stainless Steel	GX5CrNiMo19-11	1.4408	
4.2	Lower shaft				19	Segment			
	Stainless Steel	X4CrNiMo16-5-1	1.4418			Stainless Steel	X6CrNiMoTi17-12-2	1.4571	nitrite
5	Seat ring				20	Seal			
	R-PTFE	PTFE-Compound				Graphite			
	Inconel	Inconel 625				PTFE			
6	Shaft bearing					NBR			
	Stainless Steel	X6CrNiMoTi17-12-2	1.4571	nitriert 316 Ti		FPM			
	Stainless Steel	X5CrNiMo17-12-2	1.4401/PTFE	316	21	Hex.-socket screw			
7	Gland flange					Stainless Steel	A4-70		
	Stainless Steel	G-X5CrNiMo19-11	1.4408	CF8M	22	Bracket			
8	Thrust collar					Stainless Steel	GX5CrNiMo19-11	1.4408	
	Stainless Steel	X5CrNi18-10	1.4301	304	23	Hex. bolt			
9	Spacer sleeve					Stainless Steel	A2-70		
	Stainless Steel	X6CrNiMoTi17-12-2	1.4571	316 Ti	24	Hex. nut			
10	Suppor. washer					Stainless Steel	A 2		
	Stainless Steel	X6CrNiMoTi17-12-2	1.4571	316 Ti	25	Shaft adapter			
11	Set screw					Stainless Steel	GX5CrNiMoN26-7-4	1.4469	
	Stainless Steel	A4-70			26	Set screw			
12	Shaft seal					Stainless Steel	A2-70		
	Graphite				27	Centering piece			
	PTFE					Stainless Steel	X6CrNiMoTi17-12-2	1.4571	316 Ti
13	Hex.-socket screw				28	Countersunk screw			
	Stainless Steel	A4-70	1.4401	B8M		Stainless Steel	A 2	1.4301	SS
	Other materials upon request								

Subject to change without notice

HIGH PERFORMANCE BUTTERFLY VALVE HP 111-E

TORQUE

- The values specified are based on the initial breakaway torque. (disc disengages from seat, torque then drops)

DN [mm]	Size [in]	Operating pressure			
		10 [bar]		16 [bar]	
		R-PTFE	Inconel	R-PTFE	Inconel
50-65	2-2½	27	35	28	42
80	3	28	55	30	65
100	4	51	90	61	100
125	5	63	150	83	172
150	6	125	170	136	220
200	8	205	350	260	430

All values in Nm

PRESSURE/TEMPERATURE DIAGRAM

----- Pressure control line for GS-C25 body material and metal seat

— Pressure control line for 1.4408 body material and metal seat

----- Pressure control line for R-PTFE

The diagram illustrates the performance of the standard version of our valve type HP. Valves for higher pressure or deviating temperature are available upon request.

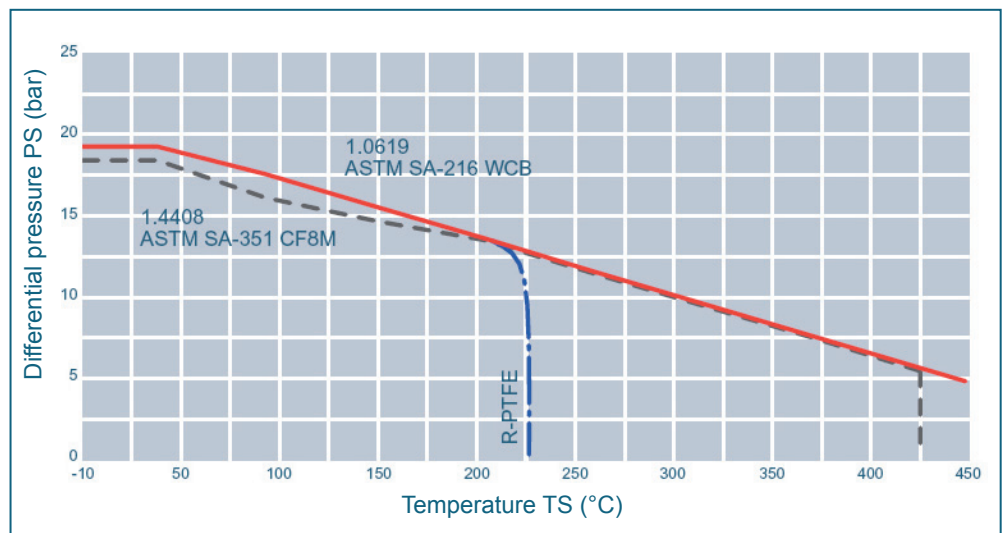

K_V-VALUES

- The K_V-value [m³ per hour] is the flow of water at a temperature of 5°C to 30°C (41°F to 86°F) at Δp of 1 bar

- The K_V-values specified are based on tests carried out by the Delfter Hydraulics Laboratories, the Netherlands

- Permissible velocity of flow
V_{max} 4,5 m/s for liquids,
V_{max} 70 m/s for gases

DN [mm]	Size [in]	Opening angle α°							
		20°	30°	40°	50°	60°	70°	80°	90°
50	2	3	13	28	39	49	58	69	81
65	2½	3	13	29	41	52	61	72	84
80	3	19	40	63	96	135	189	242	287
100	4	33	65	89	125	180	259	365	450
125	5	53	105	169	245	342	509	645	728
150	6	82	161	252	385	575	817	1010	1123
200	8	105	184	331	559	816	1217	1795	1921

Subject to change without notice

For further values, please contact our engineers.