

LUBRICATION PUMP Z2

APPLICATION

Lubrication pumps Z2 are used as a source of pressure lubricant in the circuits of two-line central lubrication systems. Pumps can be used for lubrication of high number of lubricated points, large circuits with extensive length of distribution piping and high lubricant consumption, also in the hardest operational environment.

Lubrication pump is usually used for permanent, or in combination with control unit, for cyclic lubrication of various machines, engineering technologies and equipment.

Depending on used model and number of two-line distributors pump can supply lubricant into two hundred lubricated points or more, with various dose of lubricant. If progressive distributors are used in combination with two-line system, the pump can be used for lubrication of high number of lubricated points as well as sizable total dose of lubricant into lubrication circuit and low doses into individual lubricated points at the same time. With this solution it is possible to connect mutually distant groups of lubricated point into one lubrication pumps Z2. In this case progressive distributors are placed behind two-line distributors and further divide lubricant dosed by two-line distributor into individual lubricated points.

Lubrication pumps Z2 are electrically driven piston pumps with hydraulic change-over valve integrated at the pump body. Pumps are fitted with safety valve with output pressure adjustment and pressure gauge.

Pumps Z2 are supplied for both grease and oil, with metal reservoir of various sizes 40, 63 and 100 litres. A delivery flow rate of 200 or 400 cm³/min. is also selectable. Standard electric motors are 230/400V, 500V and 415V, for other voltages, consult the supplier.

DESCRIPTION

The main part of the Z2 lubricator is a body containing a piston pump with four working pistons in two separate pumping units. The pump is driven through a single-stage worm gearbox by a flange mounted electric motor fitted to the side of the body. A hydraulic control unit is situated on the front of the lubrication pump body. This consists of: a hydraulic change-over valve connected to the body by a slide insert and connecting flange, a by-pass valve with regulating nut, a pressure gauge and an electric switch. Four venting screws are situated on the upper part of the slide insert. A steel plate lubricant container is also fastened vertically to the body. In order to improve plastic lubricant pumping as well as suction efficiency there is a scraper blade in the pump container and oblique compression areas to direct the plastic lubricant into the suction space. An electric sensor to signal minimum lubricant level is built into the lower part of the container. In addition, an electric sensor to signal maximum lubricant level can be fitted in its upper inside. A filling hole with connecting piping is situated in the lower cross part of the storage bin. The lubricator is a unit screwed on the foundation frame. There are four 13 mm dia holes in the frame for fastening to the foundation with four 12 mm dia. anchor bolts. Two outlets to the lubrication circuit are situated on the front of the hydraulic control.

OPERATION

The electric motor connected to the electric supply drives an eccentric shaft in the pump through the gearbox. Through the connecting rods, a straight reverse motion of guiding pistons connected with the working pistons occurs. When the piston moves out from the pumping unit barrel, low pressure and lubricant suction occur. While moving in the lubricant is forced out through the piston and ball check valve into the union flange, into the hydraulic change-over valve ensuring alternate supply of the lubricant into both circuit branches and further to the by-pass valve. From the hydraulic change-over switch the lubricant is forced

out into the outlets to which the piping of two-line lubrication system is connected. The working pressure is adjusted by the regulating nut on the by-pass valve.

SERVICE AND MAINTENANCE

The lubrication pump is mounted by four M12 anchor bolts on a horizontal concrete or steel foundation. Check if lubricant reservoir is clean. Move the scraper by hand to make sure that there are no impurities. Fill the lubricator with prescribed lubricant. According to current standards the electric motor is connected to the electric circuits and to the level signalling or terminal switch. Set the lubricator in operation and check to see that its running is smooth and regular. Remove lubricant which remained in the lubricator as preservation means after the pressure test.

Bleed the lubrication pump by the means of the 4 venting screws. When lubricant flows out of both outlets regularly and without air bubbles (it is necessary change over branches, by plugging the active outlet), close the both outlets by connecting them to the lubricating circuit piping. Pressure adjustment is done on the relief valve according to the lubrication circuit requirement.

It is necessary to refill the lubricant if the level drops to the narrowing part of the tank. If the lubricant is fully pumped out it is recommended to disconnect the outlets from the pipes and execute the venting of the pump including the hydraulic control unit again.

Fill up lubricant through filling valve which is positioned on the lower part of the tank. The lubricant can also be filled directly into the storage bin. Remove lid to do so. On doing this, make sure that lubricant is free from dirt.

The lubrication pump does not need any other maintenance except for refilling the lubricant. In the case of permanent operation check the lubricating circuit piping for leakage every three months.

TECHNICAL DATA

Maximum working pressure	400 bar	
Working pressure	350 bar	
Regulating range of working pressure	50 to 380 bar	
Regulating range of safety valve pressure	50 to 380 bar	
Nominal output	200 cm ³ min ⁻¹ , 400 cm ³ min ⁻¹	
Lubricant reservoir capacity	40, 63, 100 dm ³	
Number of outlets	2	
Outlet pipe union	M16x1.5 mm	
Electric motor	230/400V, 500V, 50 Hz, 0.75 kW, 1.8 A	
Alarm nominal voltage	24V DC, 2 A	
Lubricant	grease	max. NLGI - 2
	oil	min. 50 mm ² s ⁻¹
Temperature of working environment	- 25 to 40 °C	
Weight	125 kg	

NOTE

Except for models listed below further modifications and specific customized executions of lubrication pump Z2 are possible.

Alternatively it is possible to use pump Z1 in combination with external electric change-over valve (e.g. DPE). In this case the pump is installed together with change-over valve on a bedplate and this set (lubrication unit) is fitted with filtration for distant filling of pump reservoir, electric distribution box to ease wiring, and possibly with control timer for two-line system.

TYPE IDENTIFICATION KEY

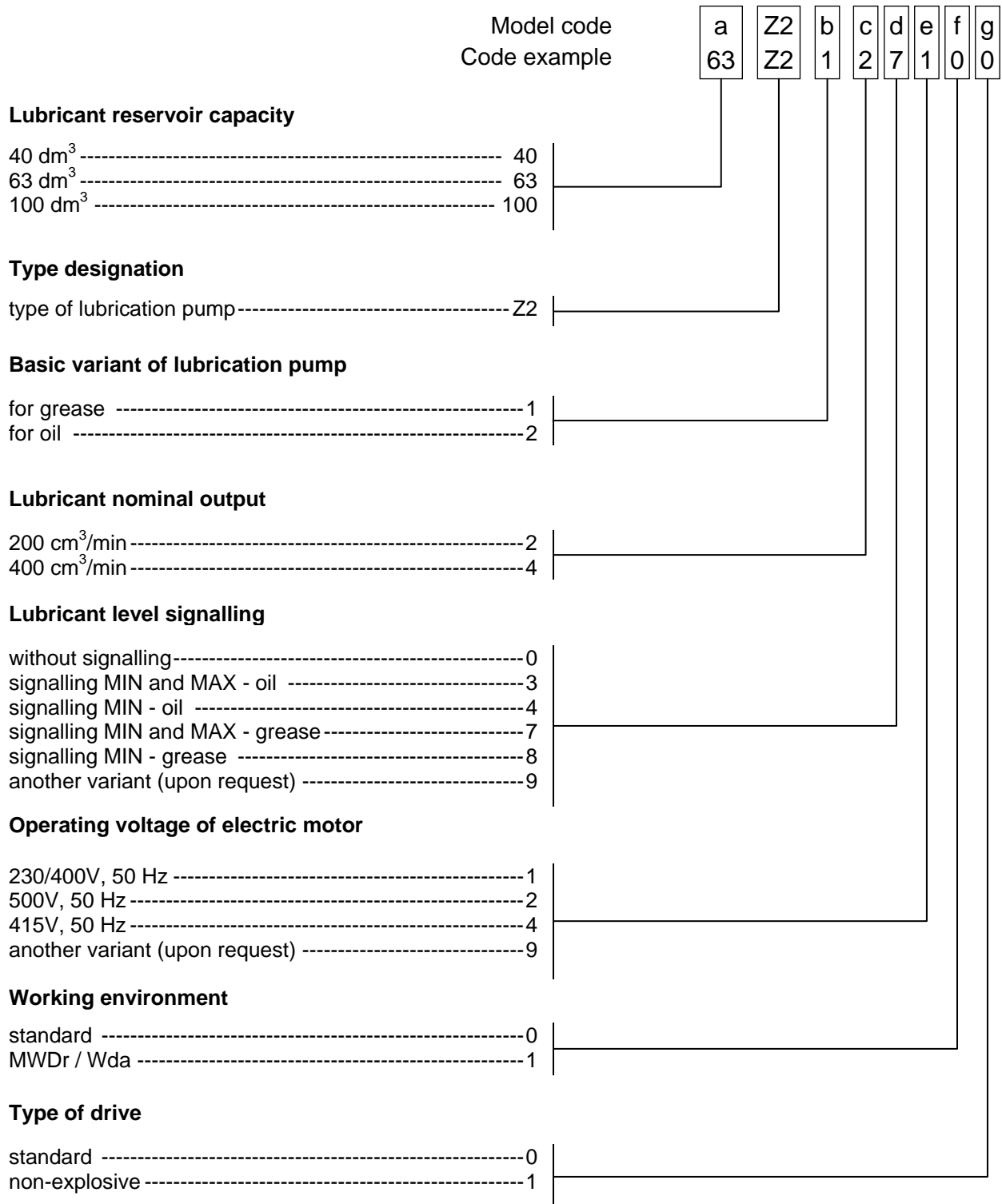

MODEL CODE EXAMPLE **63 Z2 - 12 - 7 - 100**

Lubrication pump Z2, for grease, with reservoir capacity 63 dm³, with nominal output 200 cm³/min, ultrasonic level signalling MIN and MAX for grease, electric motor 230/400V - 50 Hz, standard working environment, standard type of drive.

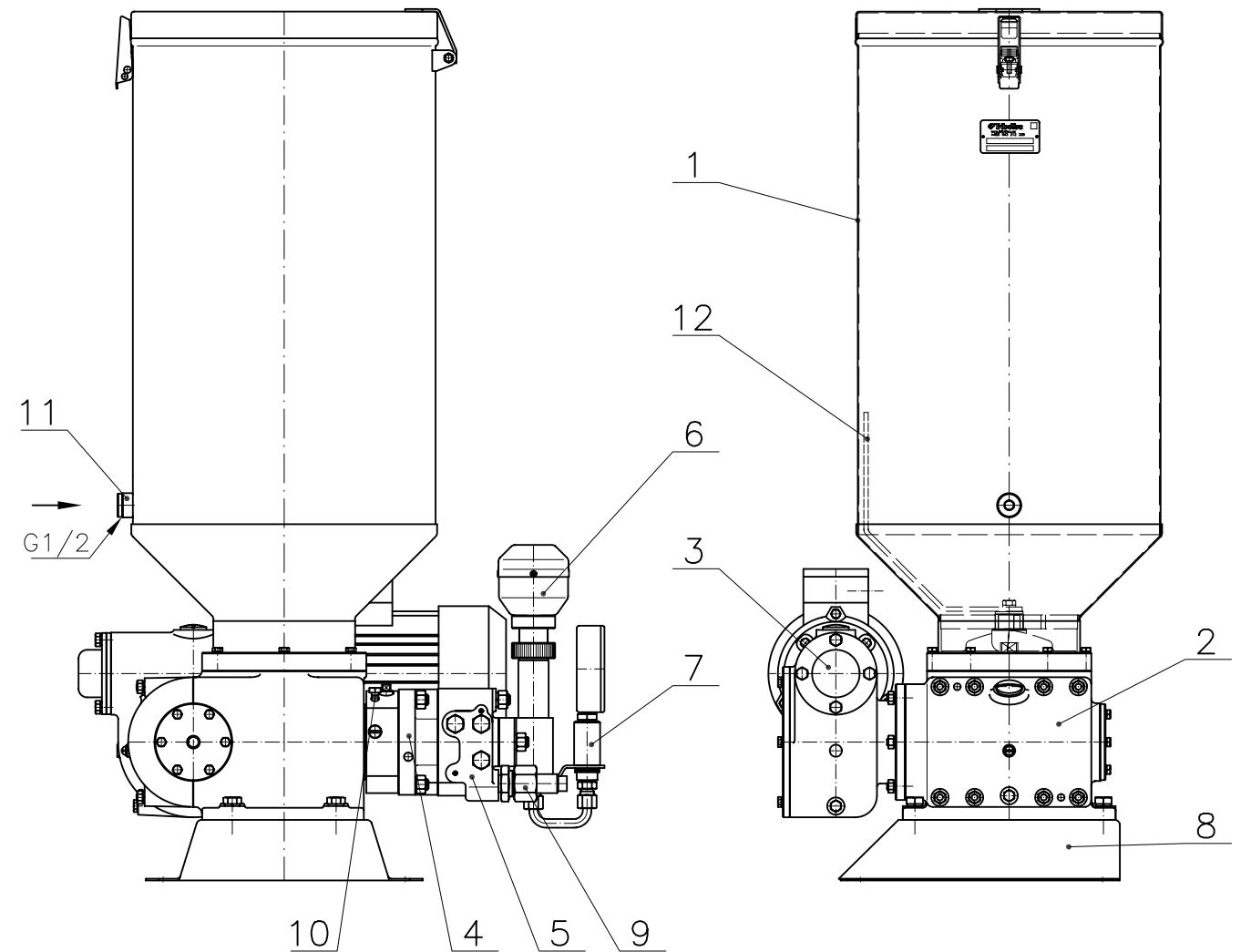
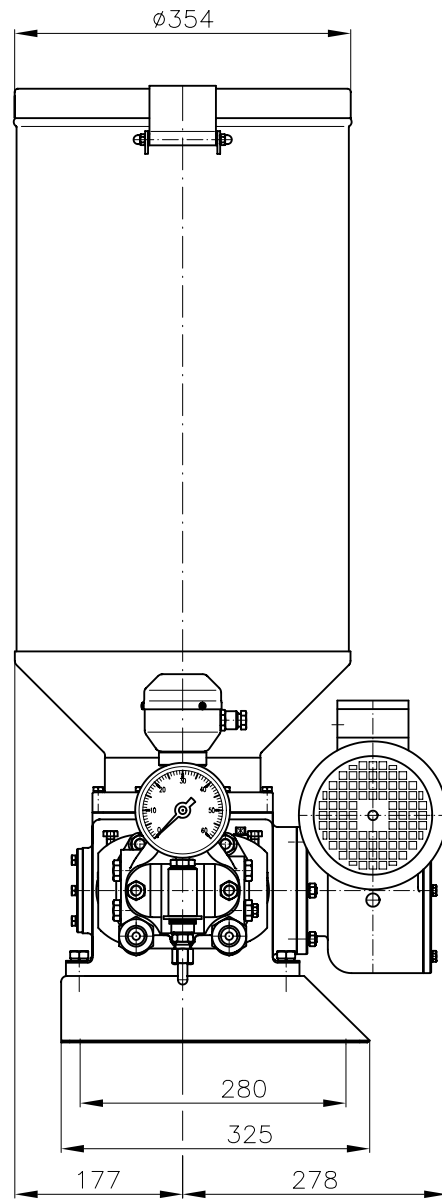
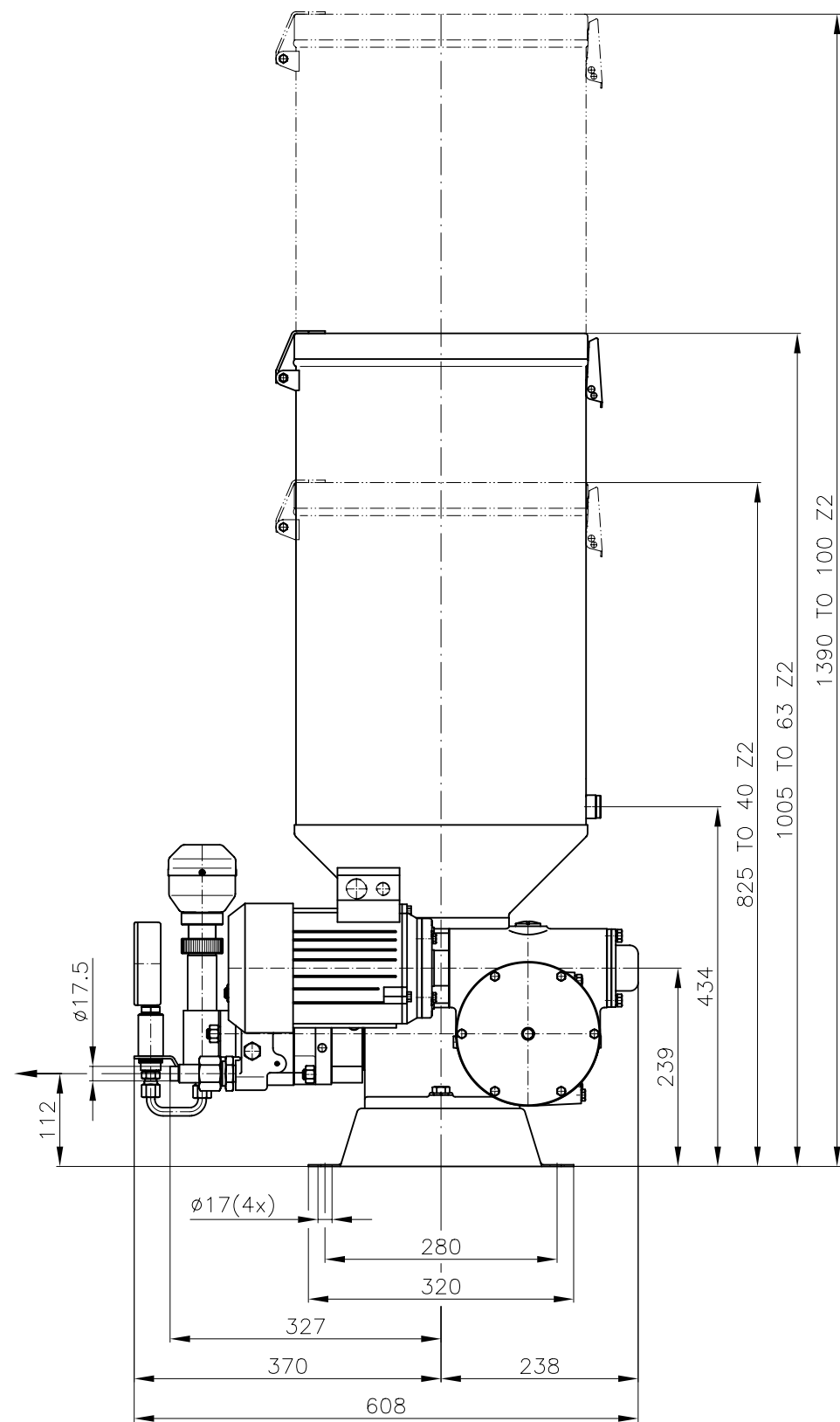

Pos	Name
1	Lubricant tank
2	Piston pump
3	Gearbox
4	Connecting flange
5	Pressure change-over valve
6	By-pass valve

Pos	Name
7	Pressure gauge damper
8	Foundation frame
9	Outlets (outlet screwed fitting)
10	Venting screws
11	Filling hole
12	Scraper blade

Name	LUBRICATION PUMP	Tribotec s.r.o. Košuličova 4 Brno www.tribotec.cz +420 543 425 611
Type	63 Z2, (40 Z2), (100 Z2) BASIC VARIANT	
Code	ACCORDING TO VARIANT	

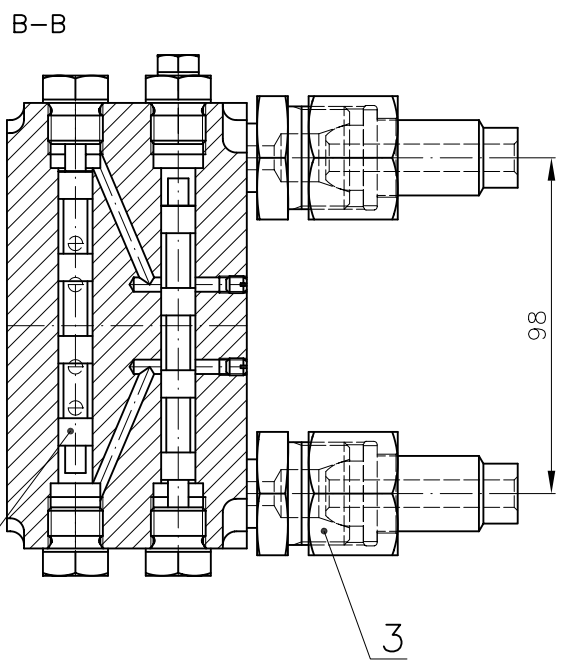
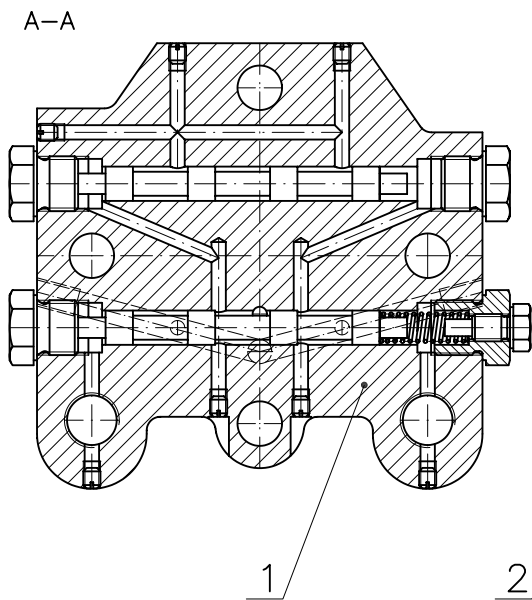
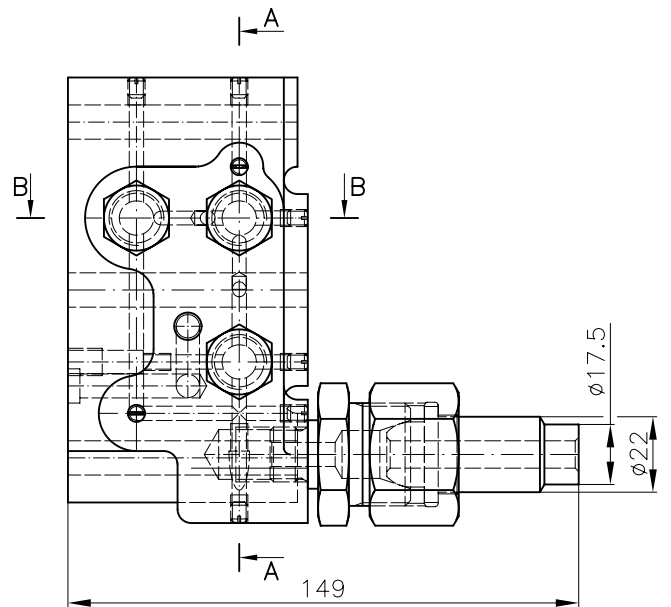
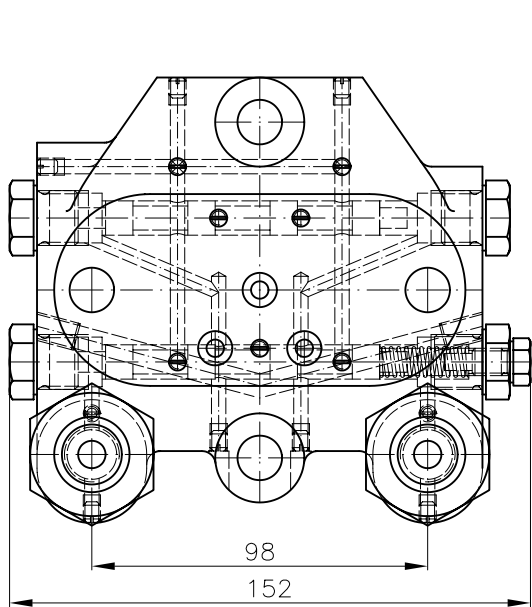

Pos	Name
1	Body
2	Hydraulic valve
3	Outlet screwed fitting

Name	PRESSURE CHANGE-OVER VALVE	Tribotec s.r.o. Košuličova 4 Brno www.tribotec.cz +420 543 425 611
Type	Z2	
Code	8 52 0011	

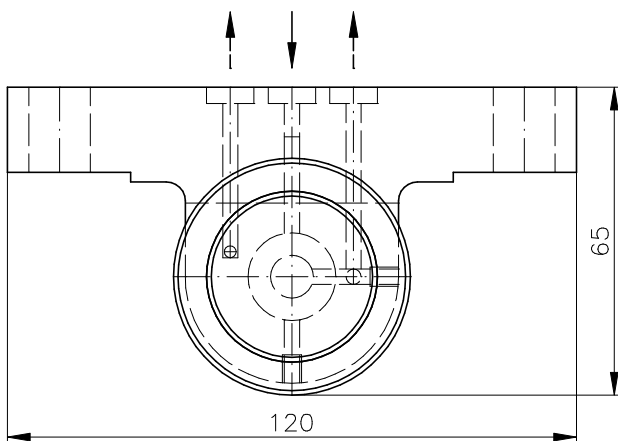
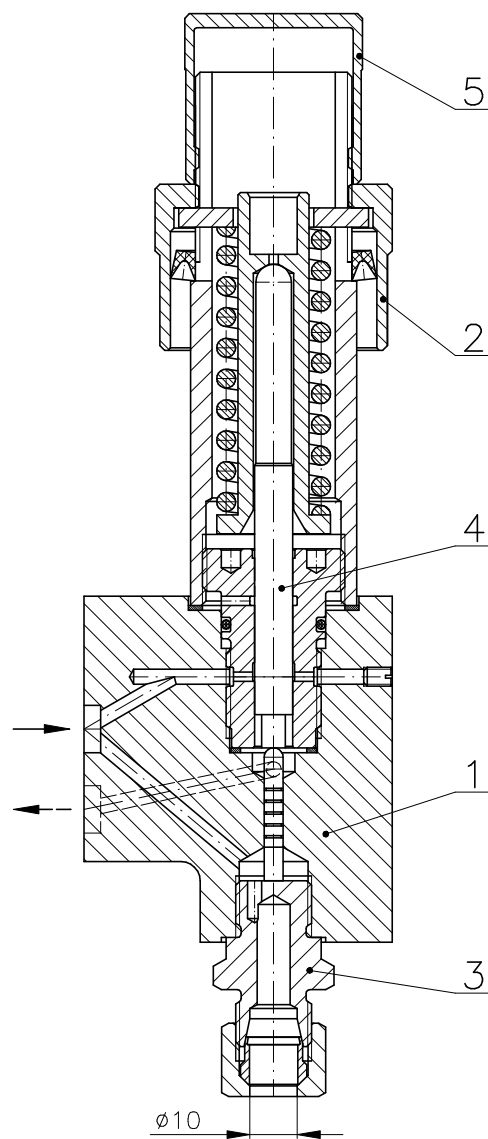
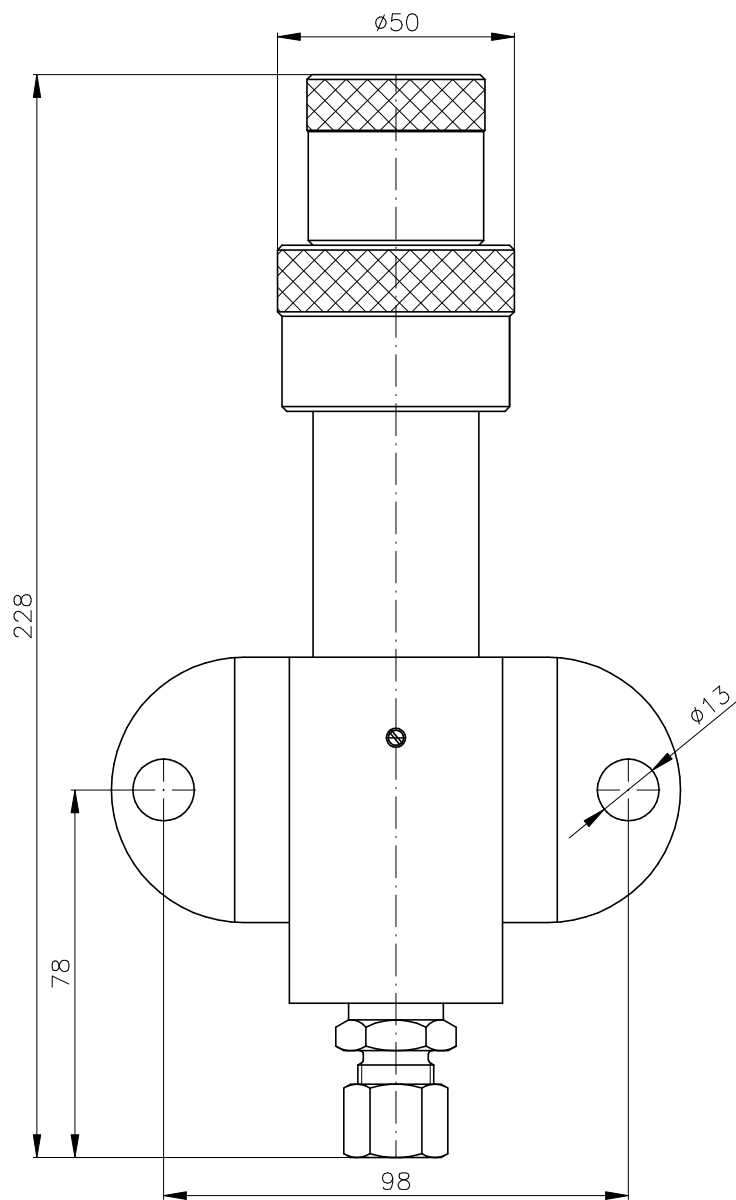

Pos	Name
1	Valve body
2	Regulating nut
3	Outlet into pressure gauge
4	Adjusting piston
5	Safety nut

Name	BY-PASS VALVE	Tribotec s.r.o. Košuličova 4 Brno www.tribotec.cz +420 543 425 611
Type	Z1, Z2	
Code	8 53 3243	

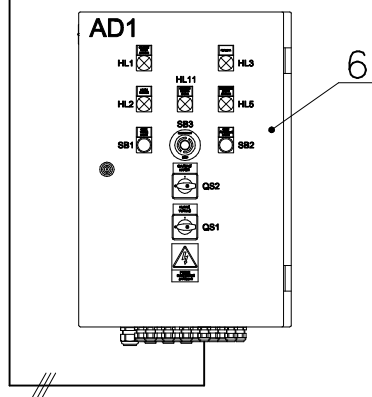
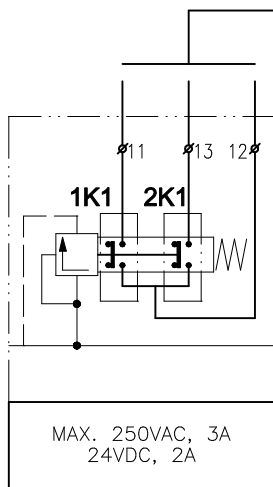
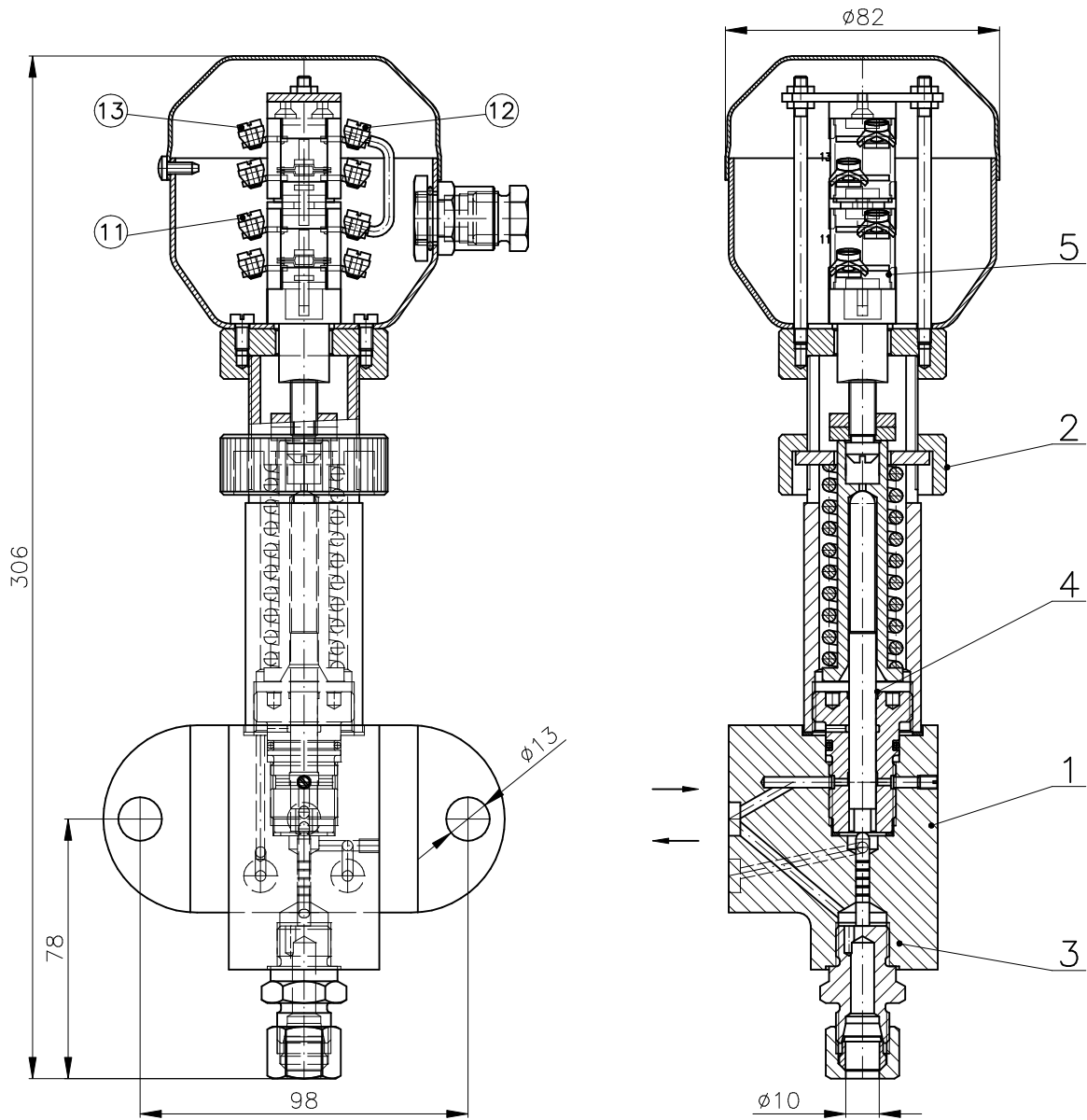

Pos	Name
1	Valve body
2	Regulating nut
3	Outlet into pressure gauge
4	Adjusting piston
5	Switching device
6	Control timer AD1

Name	BY-PASS VALVE	Tribotec s.r.o. Košuličova 4 Brno www.tribotec.cz +420 543 425 611
Type	Z2	
Code	8 53 0211	

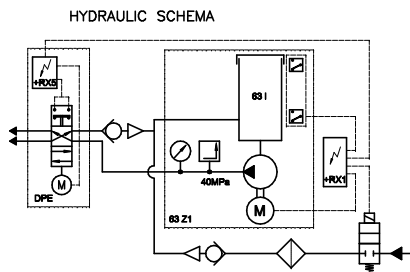
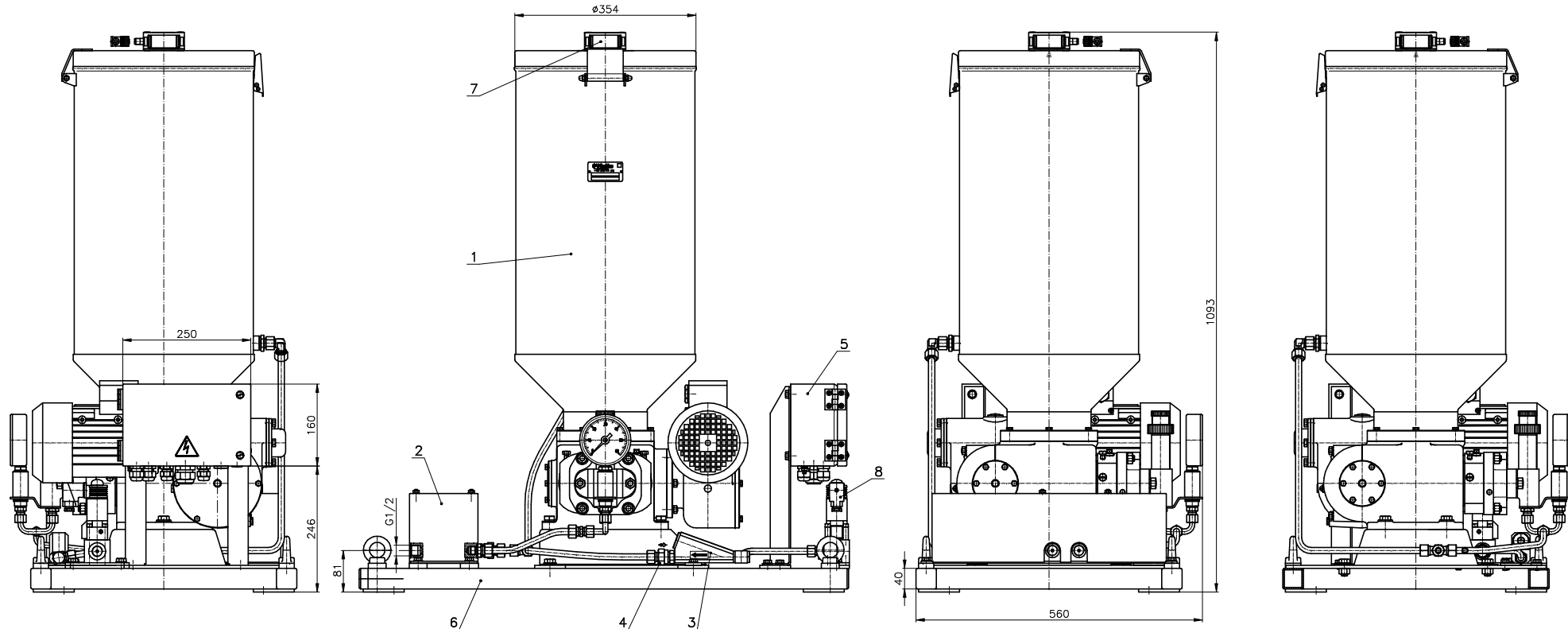

WIRING DIAGRAM

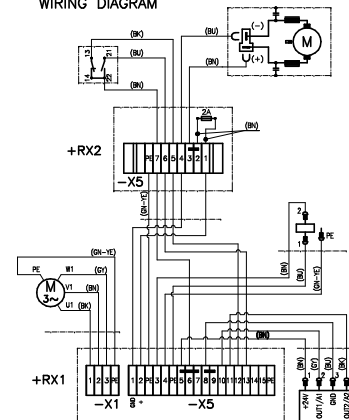

Pos	Name
1	Lubrication pump 63 Z1
2	Two-line change-over valve DPE
3	Grease strainer FLD
4	Check-valve
5	Cable box
6	Base frame
7	Ultrasound level signalling UB
8	Solenoid valve SV1 - 2/2 G1/2

Name	TWO-LINE LUBRICATION UNIT	Tribotec s.r.o. Košuličova 4 Brno www.tribotec.cz +420 543 425 611
Type	63 Z1	
Code	CUSTOM LUBRICATION PACK	