



Vacuum generation | Oil-free vacuum pumps

Rotary vane vacuum pumps – oil-free

Rotary vane vacuum pumps – oil-free

Handling in dry areas



Product notes

- > High reliability and low maintenance costs due to simple design
- > Universal application: Continuous operation at different vacuum levels
- > Compact design due to robust protective housing that also reduces the sound level
- > Protection class IP55
- > Complies with energy efficiency class IE3 according to EC regulation 640/2009
- > Please use item no. with index -A (e.g. DT.60C-3-A) for 60 Hz power frequency
- > Included in scope of delivery:
 - Safety filter on suction side
 - Silencer on pressure side
- > Electric cables not included

Technical data

Item no.	DT.60C-3 (50 Hz)	DT.80C-3 (50 Hz)
Suction power at 50 Hz [m ³ /h]	60	80
Suction power at 60 Hz [m ³ /h]	70	90
Final pressure abs. [mbar (psi)]	120 (1.7)	120 (1.7)
Power supply at 50 (60) Hz [V]	Delta: 230 (230) Star: 400 (460)	Delta: 230 (230) Star: 400 (460)
Current consumption at 50 (60) Hz [A]	Delta: 5.6 (7.6) Star: 3.2 (3.8)	Delta: 8.6 (11.8) Star: 5 (5.9)
Rated power at 50 Hz [kW]	1.5	2.2
Rated power at 60 Hz [kW]	1.8	3
Noise level at 50 Hz [dB(A)]	70	72
Noise level at 60 Hz [dB(A)]	72	74
Operating temperature at 50 Hz [°C (°F)]	70 - 73 (158 - 163)	72 - 78 (162 - 172)
Operating temperature at 60 Hz [°C (°F)]	72 - 75 (162 - 167)	75 - 80 (167 - 176)
Weight [kg]	66	71
Suitable accessories	Spare part kit: KIT-DT.60C Silencer: 72.003 Pre-filter: FC 30F	Spare part kit: KIT-DT.80C Silencer: 72.003 Pre-filter: FC 35F



Dimensions

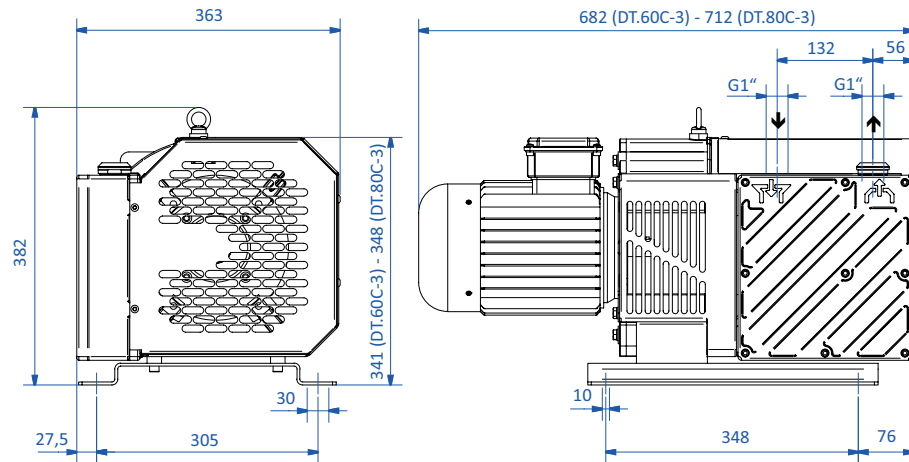

Diagrams

> Suction power against vacuum level at 50 Hz

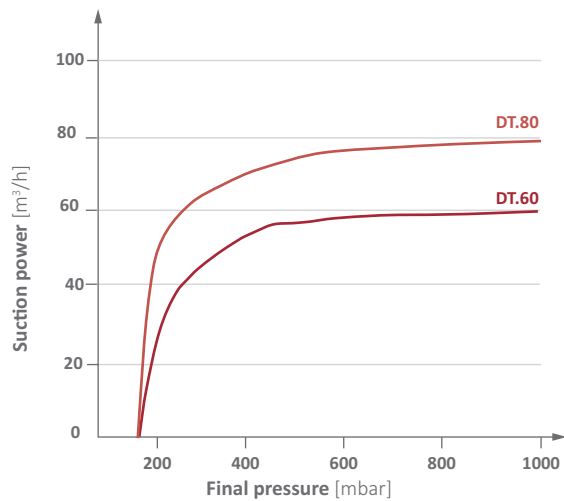

> Suction power against vacuum level at 60 Hz

